

ARPEGE EcoDesign

PANADERO

PLUS PRODOTTO

ECODESIGN



**PRESA D'ARIA
ESTERNA**



**DOPPIO CORPO IN
ACCIAIO DI 5 + 3 MM**



**FOCOLARE RIVESTITO
IN VERMICULITE**



**PORTA IN VETRO
SERIGRAFATO**



**VOLUME DI
RISCALDAMENTO**



**TRONCHI FINO A
80 CM**



PORTA LEGNA



**VETRO SEMPRE
PULITO**



**TRIPLA
COMBUSTIONE**

MISURE

DIMENSIONI A x A x L **873x1091x468 mm**

PESO LORDO/NETTO **148/139 kg**

DIMENSIONI PORTA **870x300 mm**

DIAMETRO SCARICO FUMI **Ø 150-153 mm**

Verticale

CARATTERISTICHE

GRIGLIA IN GHISA

POTENZA **8,9 KW**

RENDIMENTO **80,8 %**

EMISSIONI DE CO **0,10 %**

VERNICE ANTICALORE
RESISTENTE A **800°C**

VETRO VITROCERAMICO
RESISTENTE **750°C**

EAN 8426964180213
REF. PANADERO 18021

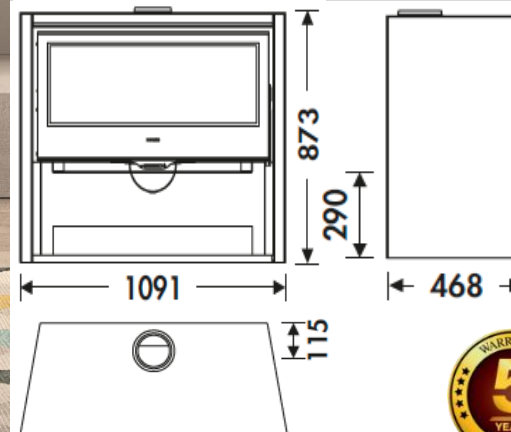

A+



Art.15a B-VG BImSchV2



*flamme
VERTE*

Le label
du chauffage
au bois

7 ★



ARPEGE IT